

INSTRUCTION MANUAL

**Super Deluxe AM/FM/SSB
25-Channel Base Station**

Model KRACO 2555 FM

STRÖMSTÄLLAREN ÄR
SEKUNDÄRT KOPPLAD OCH
SKILJER INTE APPARATENS
NÄTTRANSFORMATOR FRÅN
220 VOLTS NÄTET

INTRODUCTION

Thank you for your confidence in selecting Kraco two-way radio equipment. We know you'll find your transceiver as exciting as it is practical. Many years of valuable experience designing electronic products are behind our two-way communications systems. Only the highest quality components are incorporated into Kraco radios to assure reliability and maximum performance.

Installing and operating the *Kraco 2555 FM* is not complicated, but the flexibility provided by its numerous operating features may not be fully appreciated until a little time is spent becoming familiar with its controls and connections.

It will be to your advantage to save all the packing materials — cartons, fillers, cushioning, etc., they will prove valuable in preventing damage should you ever have occasion to transport or ship your equipment.

**INSTRUCTION MANUAL
FOR
KRACO 2555 FM
SUPER DELUXE AM/FM/SSB
BASE STATION**

KRACO 2555 FM SPECIFICATIONS

GENERAL

Channels	23 channels + channel 11A + SSB channel 24 (25 in all)
Frequency Range	26.965 to 27.255 MHz
Frequency Control	Phase locked synthesizer
Frequency Tolerance	$\pm 0.005\%$
Frequency Stability	$\pm 0.003\%$
Operating Temperature Range	-30°C to $+50^{\circ}\text{C}$
Microphone	Plug-in [4-pin], 600 Ohm dynamic
AC Input Voltage	220V, 50/60 Hz
AC Power Consumption	75W
Antenna Connectors [A and B]	Standard American [SO-239] type
Semiconductors	5 ICs, 2 FETs, 55 Transistors
Meter #1	Indicates received signal strength
Meter #2	Indicates relative RF power output/antenna SWR

TRANSMITTER

Power Output [at 220V AC]	3.5W — AM, 3.5W — FM, 12W [PEP] — Single sideband
SSB Generation	Dual balanced modulation
AM Modulation	High and low level class B collector modulation
FM Deviation	± 1.5 kHz at 1.25 kHz 20 mV audio
AM Modulation Capability	95% typically
Harmonic Suppression and Spurious Emission	60 dB down
AM/FM Frequency Response	400 to 5000 Hz
SSB Frequency Response	400 to 3000 Hz
Output Impedances [A and B]	50 Ohms, unbalanced
Output Indicators	RF Meter shows relative RF output power

RECEIVER

Sensitivity	1 μV for 10 dB S/N — AM 1 μV for 20 dB S/N — FM 0.3 μV for 10 dB S/N — SSB
Selectivity	5 dB at 4 kHz, 50 dB at 10 kHz — AM/FM 5 dB at 2 kHz — SSB
Image Rejection	More than 50 dB
IF Rejection	More than 80 dB at 455 kHz
AGC	Change in audio output less than 12 dB from 10 μV to 0.4V
Squelch	Adjustable — threshold less than 0.7 μV
Audio Frequency Response	400 to 2500 Hz
Distortion	Less than 10% at 2 watts output
Adjacent Channel Rejection	More than 75 dB at 0.3 μV
Cross Modulation	More than 50 dB
Intermediate Frequency	10.695 MHz, 455 kHz — AM/FM 10.695 MHz — SSB
Clarifier	± 800 Hz
Noise Blanker	IF single gate type
Audio Output Power	More than 2 watts into 8 ohms
Built-in Speaker	8 ohms, dynamic
External Speaker [optional]	Disables internal speaker when connected

PUBLIC ADDRESS [PA] SYSTEM

Power Output	2 watts into external speaker
External Speaker for PA [optional]	When PA switch is in PA mode, the unit functions as a public address system

SECTION I INSTALLATION

LOCATION

Place the transceiver in a convenient operating location close to an power outlet and the antenna lead-in cable(s). To prevent fire or shock hazard, do not expose this appliance to rain or moisture.

Caution: Do not expose the base station to water or moisture — example, near bathtub, laundry sink, wet basement, swimming pools, etc.

CONNECTIONS

The transceiver is supplied with an AC power cord set. Proceed as follows to complete all necessary connections to the transceiver.

1—Your transceiver has two standard antenna connectors of type SO-239 located on rear panel, for easy connection to standard PL-259 coax plugs. If the coax antenna cable must be made longer, use coax cable with impedance of 50 ohms, frequency ratings for 27 MHz, and use shortest cable length to suit your needs. This will insure a proper impedance match and maximum power transfer from the transmitter to the antenna.

2—AC Power Operation: Use 220 volts AC power for base station operation. Plug AC power cord plug into a working 220 volts household outlet.

NOISE INTERFERENCE

There are several kinds of noise interference you may encounter in base station operation. Some of these noise sources are; fluorescent buzz, nearby commercial broadcast, electrical appliance, lawnmower, and electrical storms, etc. Commercial products are available to reduce interference from these sources. Consult your dealer or CB/amateur radio supply shops.

ANTENNAS

For best transmission and reception, your CB transceiver should use an antenna especially designed for frequency band of 27 MHz. Antennas are purchased separately and include installation instructions. Numerous types of CB antennas are available that range from emphasis on each of installation to emphasis on performance. Often the difference in performance between many of the antenna is modest. You can connect 2 antennas to your CB, or 1 antenna and one dummy load.

1—Vertical Ground Plane Antennas.

These are omnidirectional antennas that provide optimum performance for contacting other fixed stations using vertical type antennas in addition to all mobile stations. For medium-long range communications work.

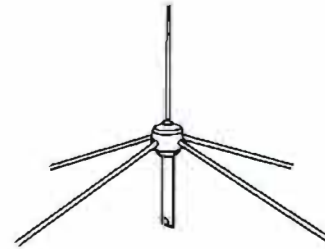

GROUND PLANE

2—Directional Beam Antennas.

Highly efficient and directional antennas generally intended for fixed-to-fixed very long range communications.

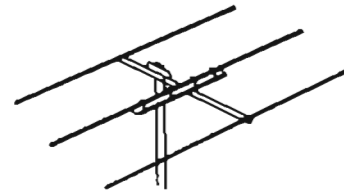

DIRECTIONAL BEAM
ANTENNA

REMOTE SPEAKER

The external speaker jack (EXT. SP) on the rear panel is used for remote receiver monitoring. The external speaker should have 8 ohms impedance and be able to handle at least 3 watts. When the external speaker is plugged in, the internal speaker is disconnected.

Note: The insertion of a headphone for private listening into the Phone jack on the front panel will silence both internal speaker and (if used) external remote speaker.

PUBLIC ADDRESS

An external 8 ohm, 3 watt speaker must be connected to the PA SP jack located on the rear panel when the transceiver is used as a public address system. The speaker should be directed away from the microphone to prevent acoustic feedback. Physical separation or isolation of the microphone and speaker is important when operating the PA at high output levels.

SECTION II OPERATION

CONTROLS AND INDICATORS

There are 18 controls and 10 indicators on the front panel of your base transceiver.

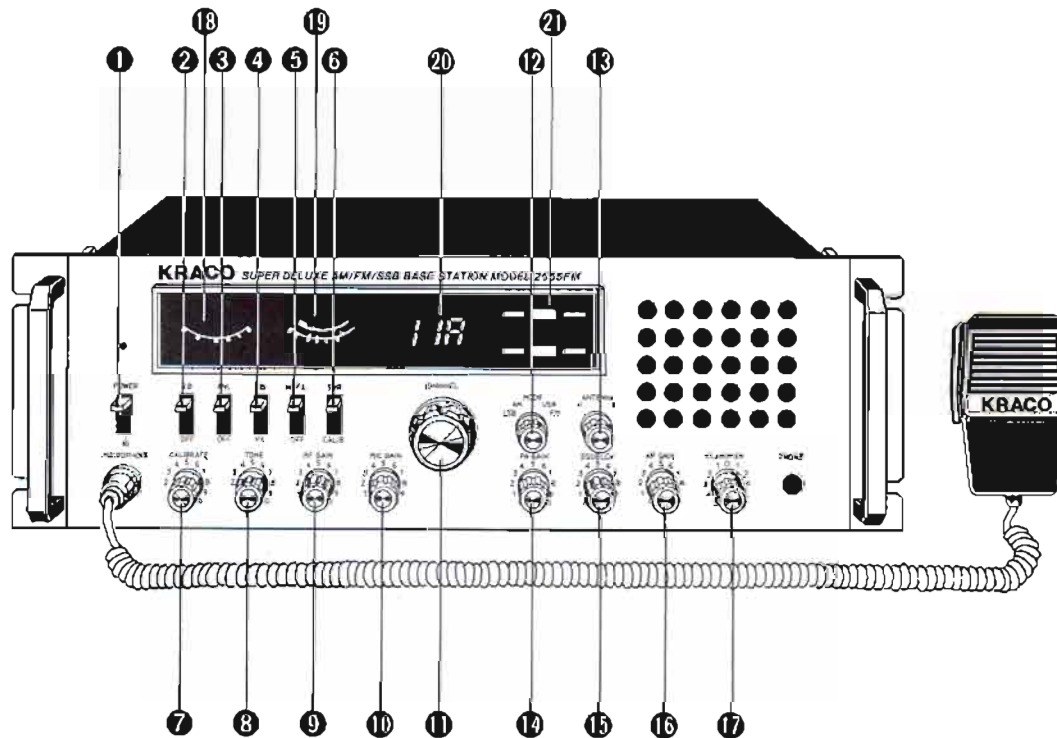

CONTROL FUNCTIONS

- 1 POWER/ON-OFF**
Place in POWER (lever up) position to apply AC power to the unit.
- 2 NB SWITCH**
This switch activates the noise blanker circuit when placed in NB (lever up) position. The noise blanker is very effective for repetitive impulse noise such as ignition interference.
- 3 ANL SWITCH**
When this switch is placed in the ANL (lever up) position, the automatic noise limiter in the audio is activated. The ANL may be used when noises generated from such sources as atmospheric discharge and/or electronic machinery are present.
- 4 CB-PA SWITCH**
This switch selects the public address mode of the transceiver. The PA function should not be used unless an external speaker is connected to the PA SP jack on the rear panel.
- 5 HIGH FREQUENCY FILTER**
This switch is used to decrease high frequency component in receiving sound output. Set the switch to lever up position when the excessive high frequency tone is noticed.
- 6 SWR-CALIBRATE SWITCH**
This switch selects the SWR meter functions:
 - CALIB (lever down): To calibrate the SWR Meter before measuring your antenna SWR ratio.
 - SWR (lever up): To read the SWR of antenna connected to the unit. See *SWR Measurement* section.
- 7 CALIBRATE CONTROL**
This control is used for the SWR meter calibration for the accurate measurement in conjunction with the SWR-CALIB Switch **6**.
- 8 TONE CONTROL**
This changes tonal sound quality when receiving. Clockwise rotation will emphasize high tone.

9 RF GAIN

This control is used to optimize reception in strong signal areas, preventing overload or distorted sound reception. Under normal operating conditions the control should be turned fully clockwise. When strong signals are received rotate this control counterclockwise to reduce gain.

10 MIC (MICROPHONE) GAIN

A preamplifier circuit is built into this unit to increase microphone gain. Experiment with this control for the setting that will best suit your individual use. This control is also used to adjust the PA volume.

11 CHANNEL SELECTOR

This control selects any one of the channels desired except channel 24. Channel 11A is located next to channel 23. The selected channel is digitally displayed in LED located above the selector. Channels 1 through 11, and 12 through 23 may be used for communications between stations operating for normal CB use in AM or FM mode. Channel 11A has been reserved for emergency communications.

Note: Channel 24 is allocated for SSB operation only and is selected automatically with the Mode Selector

12 set to either LSB or USB position.

12 MODE SELECTOR

This switch selects one of four modes of operation, AM, FM, lower sideband (LSB), or upper sideband (USB). Setting the switch to either of LSB or USB position will automatically select channel 24 (this will be shown on LED), on which SSB mode of transmission is only permitted. You cannot operate your transceiver in AM mode on channel 24, nor you cannot operate in SSB mode on other 23 channels. To operate the transceiver on other 23 channels, simply place the Mode Selector in AM or FM position.

13 ANTENNA/A-B SELECTOR

For switching between two types of antennas or dummy load that may be connected to the unit. You may connect a ground plane antenna which is non-directional to Antenna A receptacle (A position of the switch), and a beam type antenna that is highly directional to the Antenna B receptacle (B position of the switch) for long-range communications.

14 PA GAIN

The PA gain of the PA amplifier is adjustable by this control. Turn clockwise to increase the volume of PA amplifier.

15 SQUELCH

This control is used to cut off or eliminate receiver background noise in the absence of an incoming signal. For maximum receiver sensitivity it is desired that the control be adjusted only to the point where the receiver background noise or ambient background noise is eliminated. Turn fully counterclockwise then slowly clockwise until the receiver noise just disappears. Any signal to be received must now be slightly stronger than the average received noise. Further clockwise rotation will increase the threshold level which a signal must overcome in order to be heard. Only strong signals

will be heard at a maximum clockwise setting.

16 AF GAIN

Permits you to adjust the listening level when receiving.

17 CLARIFIER

This control provides precise on-frequency tuning of the receiver. On regular AM or FM reception (channel 1 through 23), this will permit adjustment of off-frequency transmissions. In the SSB mode (only on channel 24), this control is used as a voice clarifier to adjust for clearer voice reception.

INDICATORS

18 S [signal] METER

The left hand meter provides a relative indication of the signal strength of a received signal in S units during reception. The stronger the incoming signal, the further the meter pointer deflects rightwards. Note that SSB signals will respond this meter only during voice modulation. This being due to the fact that SSB transmissions do not contain a continuous RF carrier as is found on AM and FM.

19 POWER/SWR METER

Used for dual purpose: to indicate relative transmitter power when transmitting; to indicate antenna SWR [standing wave ratio]. The power meter has separate scales for AM (FM) or SSB transmission.

20 CHANNEL READOUT

This is an LED [light emitting diode] digital readout which indicates the channel selected by the Channel selector 11.

21 FUNCTION INDICATORS

LED indicators located in the LED area permit you to know instantly the mode to which the unit has been engaged.

- TX: Lights up during transmit mode indicating you are on-the-air.
- RX: Lights up during receiving mode of the unit.
- FM: Lights up when operating in FM mode with the Mode selector (12) set to FM position.
- LSB-AM-USB: Indicates a mode selected by the Mode selector (12).

PUSH-TO-TALK MICROPHONE

The receiver and transmitter are controlled by the Push-to-Talk switch on the microphone. Press the switch and the transmitter is activated; release the switch to receive. When transmitting, hold the microphone two inches from the mouth and speak clearly in a normal voice. The radio comes complete with the low impedance dynamic microphone (supplied).

Note: Depressing the Push-to-Talk switch on the microphone is also required to activate the PA system.

OPERATING PROCEDURE

Important: Make sure antenna, power source, and microphone are connected before you operate.

AM/FM RECEPTION AND TRANSMISSION

1. Set the CB-PA switch to CB.
2. Turn unit on, setting the power switch to on.
3. Set Mode Selector to AM or FM as required.
4. Set Squelch control in fully counterclockwise position.
5. Adjust AF Gain control for a comfortable listening level.
6. Adjust the Squelch control as follows:
 - a. Select a clear (unoccupied) channel using Channel selector. No signal should be present.
 - b. Increase the volume using the AF Gain control until hissing noise is heard.
 - c. Rotate the Squelch control slowly clockwise until the noise disappears.Leave the Squelch control at this setting. The squelch is adjusted properly. The receiver will remain quiet until a signal is actually received.

Note: Do not advance the Squelch control too far or some of the weaker signals may not be heard.
7. While receiving a station, rotate the Clarifier for maximum S-meter reading.
8. To transmit, depress the push-to-talk bar on the microphone and speak in a normal voice tone.

Note: You cannot choose the channel 24 on the Channel Selector while operating in AM or FM.

SSB RECEPTION AND TRANSMISSION

1. Set the CB-PA switch to CB.
2. Turn unit on, setting the Power switch to on.
3. Set the Mode Selector either to LSB or USB. Operating on LSB mode can only enable you to communicate with a station operating on the LSB mode; likewise, operating on the USB mode is the same. When you are unable to clarify the voice of received station, it is possible that the signal is not on the sideband you are using. Switch the Mode Selector to the other sideband and repeat the adjustment of the Clarifier in this mode until you are able to make the voice intelligible.

As previously stated, setting the Mode Switch to either of SSB position will automatically select channel 24 on

which you can only operate with SSB mode, regardless of the Channel Selector selection. The Channel LED will display 24. To operate on other 23 channels simply set the Mode Selector to AM or FM position.

ACCESSORY CIRCUITS OPERATION

1. **PUBLIC ADDRESS OPERATION:** To use this feature of the transceiver, a speaker having a voice coil impedance of 8 to 16 ohms and a power handling capability of at least 3 watts should be connected to the PA SP jack on the rear panel. Be sure that there is physical separation between the microphone and the PA speaker itself. If the PA speaker is located very close to the microphone, acoustic feedback will result when the PA amplifier is operated at high volume (or when used indoors).
2. **SWR MEASUREMENT:** Most antennas are factory tuned, but the antenna efficiency may be peaked by slightly adjusting the length of antenna using the SWR meter built into the unit. This adjustment may improve the antenna standing wave ratio (SWR). The SWR permits you to determine how well matched the antenna and its cables are to your transceiver.
 1. Set the unit in the receive mode as instructed under the Operating Procedure to Receive section.
 2. Set the Mode switch **12** to AM position; the SWR-Cal **6** switch to the Cal position.
 3. Pressing the Push-to-Talk switch on the microphone and turn the Calibrate Control **7** clockwise (past click) so that the SWR meter pointer exactly coincides with the Set mark on the scale. Release the Push-to-Talk switch.
 4. Set the SWR-Cal switch to the SWR position and depress the Push-to-Talk switch again. The SWR of your antenna is read directly on the scale.

Note: An SWR below 2 or less is desired as this indicates that over 95% of the transmitted power is broadcast into the air.

SECTION III MAINTENANCE AND ADJUSTMENT

Your base station transceiver is specifically designed for the environment encountered in the base station use. The use of fully solid state circuitry including the phase-locked loop circuit result in high reliability. Should a failure occur, however, replace parts only with identical parts. Do not substitute. Refer to the Schematic Diagram and PC Board Diagram in this manual.

Note: If the performance described in the OPERATION section is not obtained, review the INSTALLATION section to insure that proper procedures were followed. If a problem still exists, refer to Alignment section of this manual.

CIRCUIT DESCRIPTION

The transceiver is 24 AM/FM and 1 SSB channel base transceiver which uses phase-locked-loop (PLL) frequency synthesizing system to produce all 25 frequencies. The basic PLL system is comprised of a free-running voltage controlled oscillator (part of IC2), a phase detector, a reference crystal oscillator (Q6) and a programmable divider (IC1), as seen in the PLL Block Diagram on next page.

PLL THEORY

In the AM or FM mode, the voltage-controlled oscillator operates in the frequency range of 17.555 to 17.845 MHz, and is used to produce two output signals: #1; 37.66 MHz to 37.95 MHz #2; at 2.55 MHz to 2.26 MHz. In the SSB mode (operable on channel 24, 27.235 MHz alone), the VCO oscillates at 17.825 MHz in the USB mode and 17.8235 MHz in the LSB mode, and is used to produce 37.93 in the USB and 37.927 MHz in the LSB mode, and 2.28 MHz. Off-set frequency oscillator Q3 oscillates at a frequency of 10.0525 MHz (10.05175 MHz in the LSB on channel 24).

Its output is fed through the band-pass filter (BPF)/doubler resulting in an output signal, 20.105 MHz (20.1035 MHz in LSB mode). This signal beats with the VCO 17 MHz free-running signal, producing a 37.66 to 37.95 MHz in the

AM/FM mode and 37.93 MHz in the USB, and 37.927 MHz in the LSB mode, which is fed to the receiver first mixer (Q22) and also to IC3, the transmitter mixer. The second VCO output signal, at 2.55 to 2.28 MHz is fed to the programmable divider in IC1. Simultaneously the 10.24 MHz output of Q6 (through the buffer Q5) is applied to the programmable divider in IC1 and is divided down in 10 kHz steps. As an AM or FM channel is chosen by the Channel Selector switch [SW-1], and N code signal is applied to the terminals [pins No. 10 to 15 of IC1] on the programmable divider in IC1, to preset the divider. The two signals, the crystal oscillated signal [10.24 MHz] from Q6, and the signal from the VCO via the lowpass filter [LPF] and buffer [in the IC1], are compared in the phase detector of IC1 and the phase detector produces a DC output voltage derived from the phase difference in the signals fed to

PLL BLOCK DIAGRAM

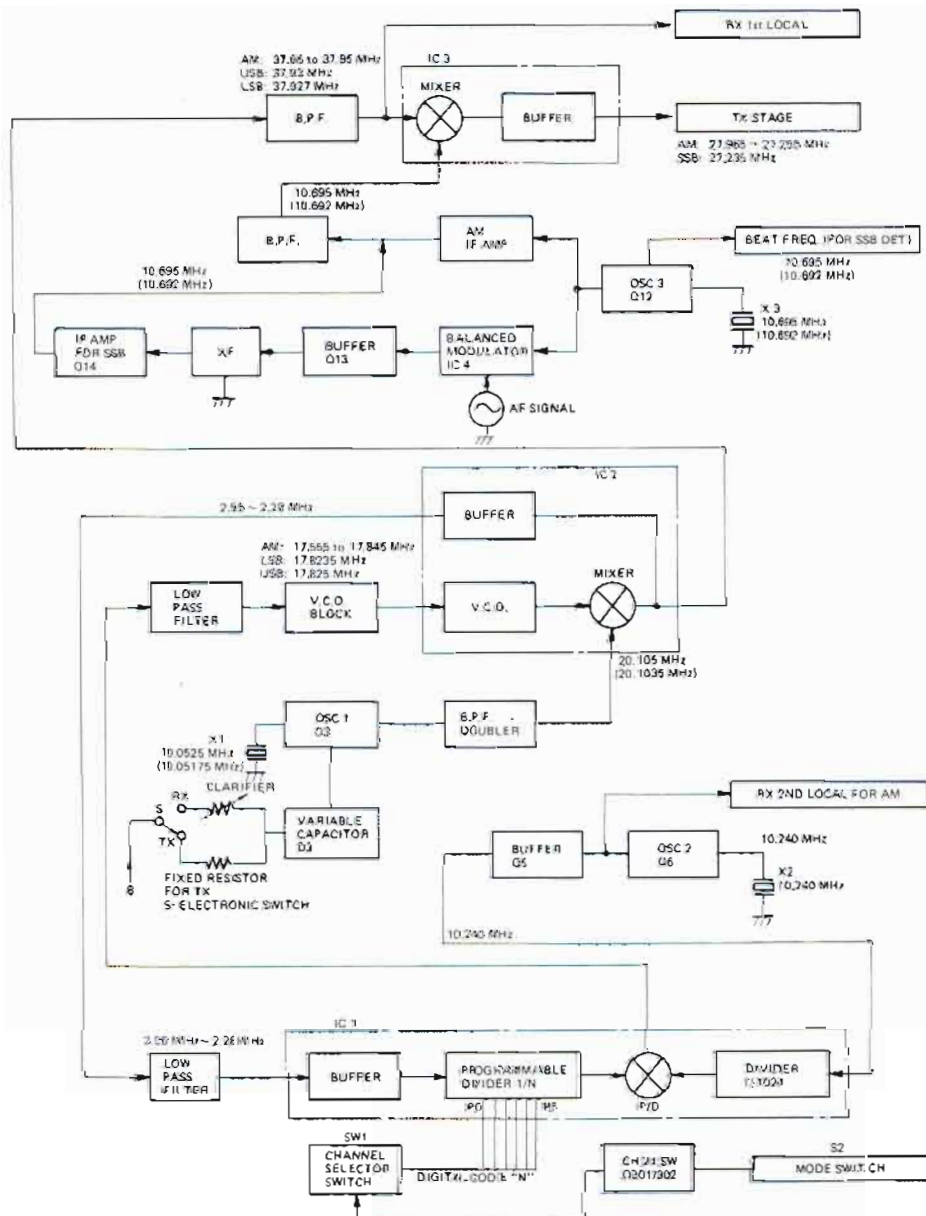

Frequency in parenthesis is for LSB mode.

IC and be fed to the AF gain control through the mode selector switch.

In the SSB mode of reception, the signal obtained as a result of the mixture of the RF input and IC2 VCO signals, 10.695 MHz IF, is not converted down to lower intermediate frequency, but is passed thru the crystal filter, XF, and fed to the SSB IF amplifier stages, Q14, 16, and 17, which includes T11, and 12. The signal at the secondary

side of T12 is fed to Q19, the product SSB detector and beaten with the BFO [beat frequency oscillator] signal from the Q12 and finally rectified to audio frequency signal.

The audio signal output from each detector for AM [D25] and SSB [Q19], is passed through the AF Gain Control, VR1, the input of the audio amplifier, IC5. The audio output is transformer-coupled to the internal speaker, or to an external speaker through External Speaker jack, J4.

SSB RECEIVER (Channel 24 only)

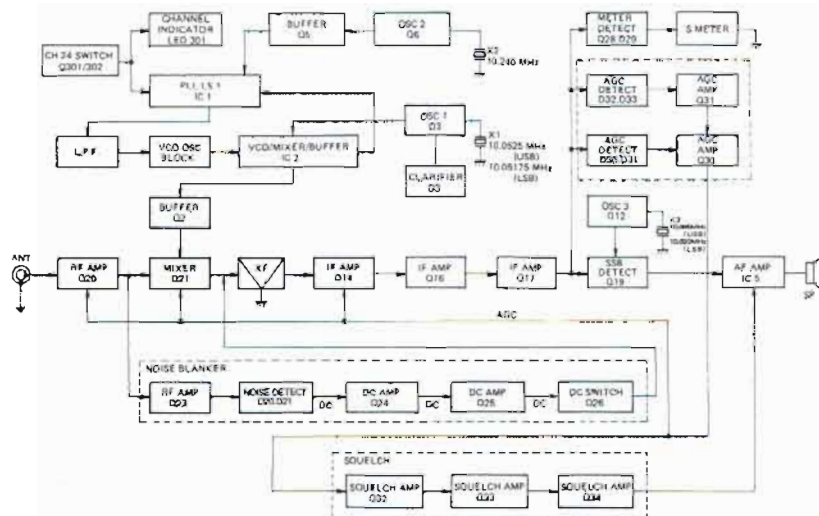

AM/FM RECEIVER (Channel 1-23)

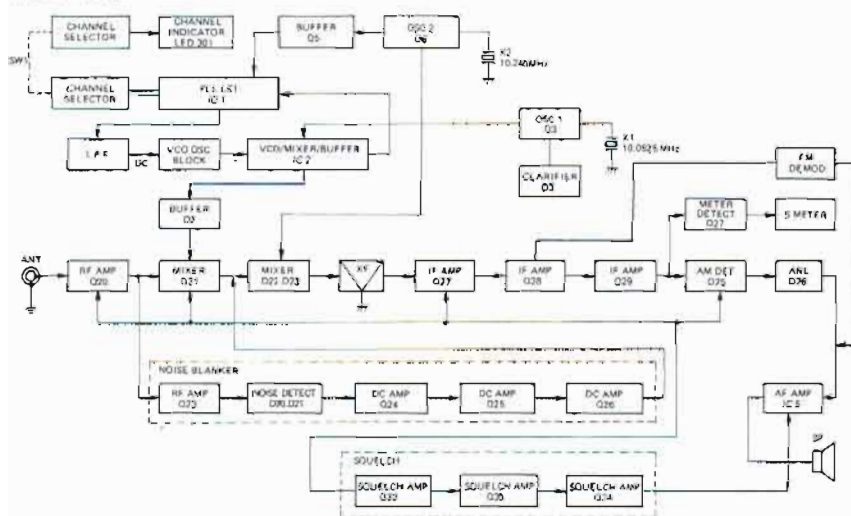

SQUELCH: Q32, 33, and 34 are the squelch amplifier transistors. At low [or no] signal levels Q34 collector conducts to ground and its output connected to pin number 7 of IC5 results in no signal output from the audio amplifier. As the incoming RF signal increases it results in opening up the AF amplifier and output is activated. The point at which Q34 cuts off is determined by setting the Squelch Control, VR2.

NOISE BLANKER: The noises contained in the RF signal at the output of RF amplifier, Q20, is fed through C112 to the base of Q23. The amplifier signal output of Q20 is rectified by diodes D20 and 21. The resulting DC voltage turns on Q24 [FET] which in turn turns on Q25 and 26. This causes the IF signal [10.695 MHz] at T10 to be conducted to ground through C121 and Q26 during the pre-

sence of the noise impulses, blanking out the noise at the receiver output.

CLARIFIER: The Clarifier circuitry is employed in the 10.0525 MHz oscillator, Q3. The Clarifier volume VR7 acts to vary the plus voltage bias of D3 [Voltage variable capacitor] so that the crystal [X1] frequency is pulled above [as VR7 rotated clockwise] or below [as VR7 rotated counterclockwise] its normal operating frequency.

PUBLIC ADDRESS: Switching provision is made in the audio input circuit of the transceiver to provide a PA function by utilizing the microphone output. In the PA mode, the transceiver serves as a public address amplifier providing 2 watts output to the external PA Speaker jack, J3.

TRANSMITTER ALIGNMENT

Connect test equipment to the transceiver as shown below.

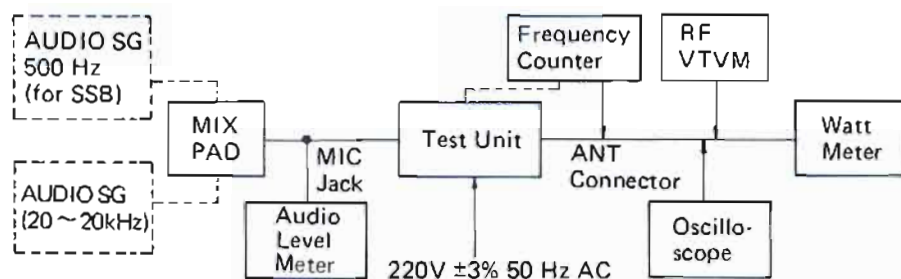

DUMMY PLUGS

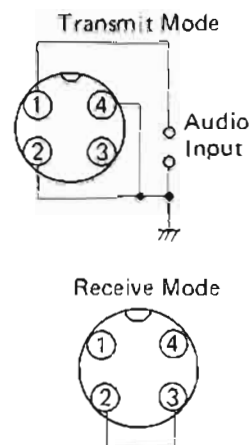

TEST EQUIPMENT

The following test equipment is required and recommended for servicing the transceiver satisfactorily.

1. A 50 Ohm resistive antenna load with a power capability of 20 watts or more.
2. A frequency counter operable in the required CB range.
3. A HF signal generator which operates in the 50 kHz to 65 MHz frequency range with $\pm 1\%$ accuracy.
4. An oscilloscope capable of accurate monitoring of

27 MHz range.

5. A digital voltmeter.
6. Dummy plugs to activate the transceiver in receive or transmit mode without using microphone, wired as shown above.
7. An 8 Ohm 5 watt resistive dummy speaker load.
8. An audio signal generator, 10 Hz to 20 kHz.
9. An RF voltmeter.
10. A 220 volt ($\pm 3\%$) 50/60 Hz AC source.

TUNE-UP AND ALIGNMENT

Before performing any adjustments, check visually all jacks, plugs and solder joints for good connection. Shown in the schematics are nominal test voltage values for the transceiver transistors and ICs. For tune-up and servicing identical procedures may be employed for all circuits. Since the transceiver is designed primarily for AC-powered base station, use AC power source with a slide line regulator adjusted to exact 220 volts.

To activate the transceiver without using the microphone, use the dummy microphone plug. This plug is also used to introduce a modulating audio signal to the microphone input circuit as described in the following procedure.

AVR ADJUSTMENT

Important: Do not short cut this adjustment. Perform this section first of all adjustments, otherwise you may risk upsetting entire alignment of the unit.

- 1) Insert AC power plug into power outlet regulated with a slide line regulator.
- 2) Turn power on and adjust the line regulator for exact 220 volts.
- 3) Adjust RV1 on PC board PTPW007COX for exact 13.2V between terminals 3 and G on the board.

PLL ALIGNMENT

- 1) Set the Mode Switch to USB position, channel 24.
- 2) Connect a frequency counter to test point TP2 through a 1000 pF capacitor.
- 3) Adjust the trimming capacitor CT3 for reading of

10.24 MHz \pm 50 Hz.

- 4) Connect both oscilloscope and frequency counter to test point TP3 [pin number 4 of IC2] and adjust the core of T3 for maximum amplitude of scope display [10.0525 x 2 MHz], then adjust CT1 to obtain 20.10500 MHz \pm 40 Hz.
- 5) Set the Mode switch to LSB and adjust CT2 to obtain the reading of 20.103500 MHz \pm 40 Hz.
- 6) Connect frequency counter to TP5 and adjust CT5 to read 10.695 MHz \pm 50 Hz in the USB mode of operation. Set the Mode switch to LSB and adjust CT4 to read 10.692 MHz \pm 50 Hz.

VCO ALIGNMENT

- 1) Set the Mode Selector to AM and Channel Selector to channel 1.
- 2) Connect a digital voltmeter [or a circuit tester, DC 12V range] between ground and TP4.
- 3) Adjust the core provided in the VCO block to obtain 3.6V \pm 0.1V, starting from top to bottom when turning the core [the circuit tester used in this procedure should be calibrated and have an input impedance of 20 kOhm/V or higher].
- 4) Next, set the Mode Selector to USB, channel 24 and verify that the reading is 2.3 to 2.7V.

RF AMPLIFIER BIAS

- 1) Connect an amperemeter between the Q10 emitter and chassis ground.
- 2) Adjust RV1 to obtain bias current of 35 mA \pm 10 mA.

RF POWER AMPLIFIER STAGE

- 1) Set the Mode Switch to USB (This selects channel 24).
- 2) Connect oscilloscope to pin number 4 of IC3.
- 3) Feed 2.4 kHz, 10 mV audio to the microphone input circuit.
- 4) Adjust T1 for maximum amplitude of scope display.
- 5) Set the Mode Selector to AM and Channel Selector to channel 1.
- 6) Remove audio input from microphone input circuit.
- 7) Adjust T2 for maximum amplitude of scope display.
- 8) Reset channel selector to channel 13 and connect the oscilloscope to the antenna receptacle in parallel with the Wattmeter.
- 9) Adjust T6, 11, 12, and 13 for maximum power output on the Wattmeter.
- 10) Set the Mode Selector to USB with audio input disconnected.
- 11) Adjust RV4 and RV5 for minimum carrier leakage on the scope display.
- 12) Feed two tones, 500 Hz and 2,500 Hz audio of 100 mV to the microphone input circuit.
- 13) Rotate RV2 fully clockwise.
- 14) Rotate RV11 slowly clockwise from the counterclockwise position to which waveform begins to clip.
- 15) Adjust RV1 so that plus sine wave swing and minus sine wave swing are crossed straight (in the shape of X). See Correct figure below.
Note: Use the output level control on the audio oscillator oscillating at 500 Hz, when you have failed to do this adjustment with RV1.
- 16) Adjust RV2 rotating slowly counterclockwise for smooth, clear sine wave appears on scope.
- 17) Repeat steps 14) and 16) alternately until 11 Watts PEP power output is obtained on Wattmeter.

CORRECT

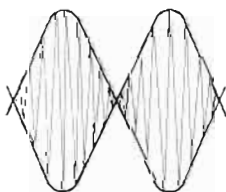

INCORRECT

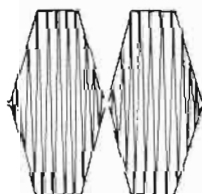

INCORRECT



AM RF POWER STAGE

- 1) Set the Mode switch to AM position, and the Channel Selector to channel 13.
- 2) Adjust VR9 for RF output of 3.7 watts on the wattmeter.

AM MODULATION ALIGNMENT

- 1) Apply 2.5 kHz, 7 mV audio signal input to the microphone input circuit.
- 2) Adjust RV12 for modulation depth of 80%.
- 3) Increase the signal input to 70 mV and verify that modulation depth is 90% or less.

RF POWER METER

- 1) Compare RF power meter on the transceiver and wattmeter externally connected in prior set-up.
- 2) Adjust RV3 so that the RF power meter provided on the unit indicates the same wattage as obtained on the wattmeter.

FM MODULATION ADJUSTMENT

- 1) Set the Mode switch to FM.
- 2) Apply 1,250 Hz 20 mV audio to modulation circuit. Use dummy microphone plug.
- 3) Connect deviation meter to antenna output on the unit.
- 4) Adjust RV501 (PTZZ050AOX) to obtain 2 ~ 3 kHz deviation.

TRANSMIT FREQUENCY CHECK

- 1) Set the transceiver to the transmit mode with no modulation condition.
- 2) Set the Mode switch to AM position.
- 3) Connect frequency counter to the antenna connector and read frequency at channels 1 thru 23. Verify that frequency is within ± 800 Hz of center channel frequency as tabulated in the PLL Frequency Table in page 16.
- 4) Set the Mode switch to USB. Feed 2.4 kHz 10 mV audio to the microphone circuit.
- 5) Verify the TX frequency (channel 24).

RECEIVER ALIGNMENT

Connect test equipment to the transceiver as shown below. To activate the receiver section without using the micro-

phone, use the dummy microphone plug wired as shown in page 13.

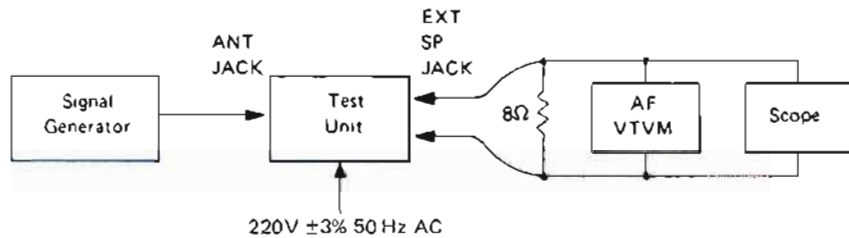

AGC

- 1) Connect digital voltmeter [or circuit tester] to terminal 15 (Q20, 22 bias) on the PC board and chassis ground.
- 2) Set the Mode switch to AM and RF Gain to max.
- 3) Adjust RV8 to obtain reading of 2V.

RECEIVER SENSITIVITY

- 1) Set the signal generator to 27.115 MHz, 1 kHz 30% modulated.
- 2) Set the transceiver to channel 13.
- 3) Adjust T7, 8, 9, 10, 13, 14, and 15 for maximum audio output across 8 Ohm dummy load resistor. This alignment should be performed with very small signal input from the signal generator to avoid inaccurate alignment due to AGC action.
- 4) After completion of step 3), rotate the T7 core so that the audio output decreases by 2 dB.

SQUELCH

- 1) Set the Mode switch to AM.
- 2) Set the signal generator to provide RF input signal of 300 μ V, 1 kHz 30% modulated and rotate the Squelch

control to the fully clockwise position.

- 3) Adjust RV9 so that the audio just appears on scope display.

S METER

- 1) Set the signal generator to provide 100 μ V output and set the Mode switch to USB.
- 2) Adjust RV7 so that the S meter pointer indicates 9 on the front panel S meter [left hand].

FM IF/DEMODULATOR ALIGNMENT

- 1) Select channel 13.
- 2) Set unit to no signal condition.
- 3) Adjust T501 and T502 (on PTZZ050AOX) repeatedly to maximum (noise) output.
- 4) Apply FM signal [1 microvolt, 1.5 kHz deviation with 1 kHz audio] to unit.
- 5) Readjust T501 and T502 (on PTZZ050AOX) for maximum audio output.

Important. When rotating T502 core from top end, maximum audio output is obtained at 3 points. Adjust to 2nd peak point.

PLL FREQUENCY TABLE

Channel No.	Channel Freq. (MHz)	"N" Digital Code	VCO Freq. (MHz)	Channel Sw. Output						RX 1st Local
				P1	P2	P3	P4	P5	P6	
1	26.965	255	17.555	1	1	1	1	1	1	37.66
2	26.975	254	17.565	0	1	1	1	1	1	37.67
3	26.985	253	17.575	1	0	1	1	1	1	37.68
4	27.005	251	17.595	1	1	0	1	1	1	37.70
5	27.015	250	17.605	0	1	0	1	1	1	37.71
6	27.025	249	17.615	1	0	0	1	1	1	37.72
7	27.035	248	17.625	0	0	0	1	1	1	37.73
8	27.055	246	17.645	0	1	1	0	1	1	37.75
9	27.065	245	17.655	1	0	1	0	1	1	37.76
10	27.075	244	17.665	0	0	1	0	1	1	37.77
11	27.085	243	17.675	1	1	0	0	1	1	37.78
12	27.105	241	17.695	1	0	0	0	1	1	37.80
13	27.115	240	17.705	0	0	0	0	1	1	37.81
14	27.125	239	17.715	1	1	1	1	0	1	37.82
15	27.135	238	17.725	0	1	1	1	0	1	37.83
16	27.155	236	17.745	0	0	1	1	0	1	37.85
17	27.165	235	17.755	1	1	0	1	0	1	37.86
18	27.175	234	17.765	0	1	0	1	0	1	37.87
19	27.185	233	17.775	1	0	0	1	0	1	37.88
20	27.205	231	17.795	1	1	1	0	0	1	37.90
21	27.215	230	17.805	0	1	1	0	0	1	37.91
22	27.225	229	17.815	1	0	1	0	0	1	37.92
23	27.255	226	17.845	0	1	0	0	0	1	37.95
11A	27.095	242	17.685	0	1	0	0	1	1	37.79
24(USB)	27.235	228	17.825	0	0	1	0	0	1	37.93
24(LSB)	27.235	228	17.8235	0	0	1	0	0	1	37.927

Note: 1, High Level = 4.5 – 5.5V
0, Low Level = 0.05 – 0.4V

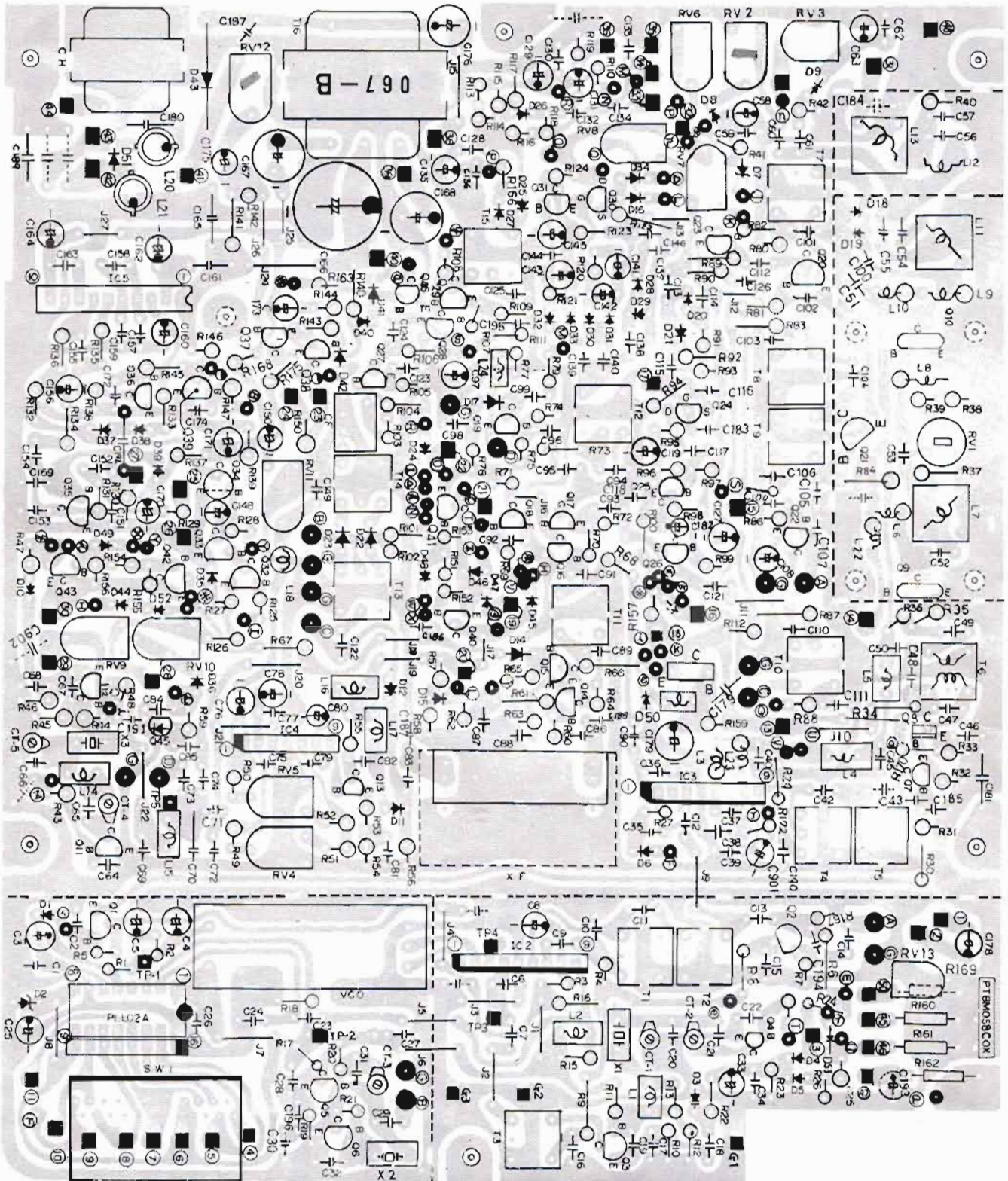

Main Assembly [PTBM058COX]

Relays Board [PTZZ024AOX]

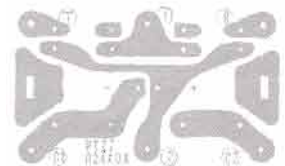

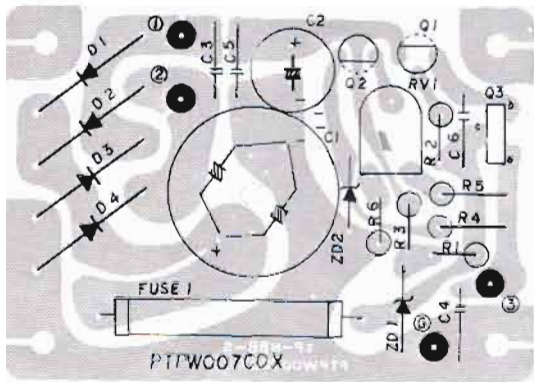

AVR [PTPW007COX]

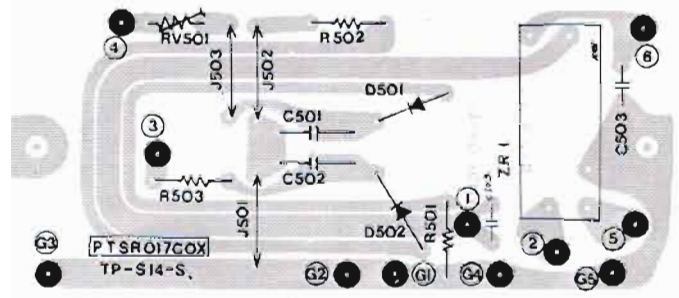

SWR [PTSR017COX]

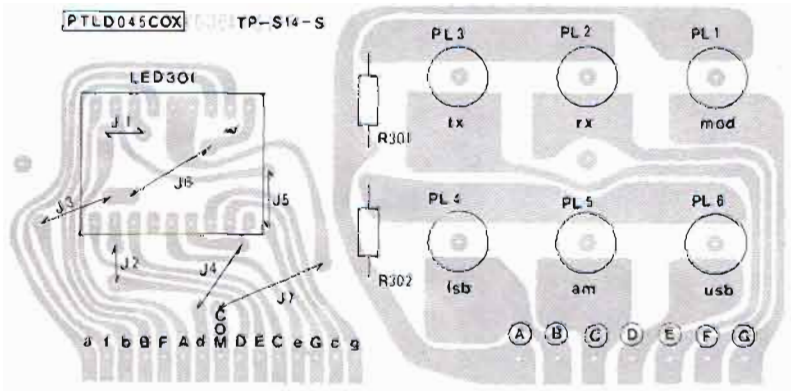

Channel LED [PTLD045COX]

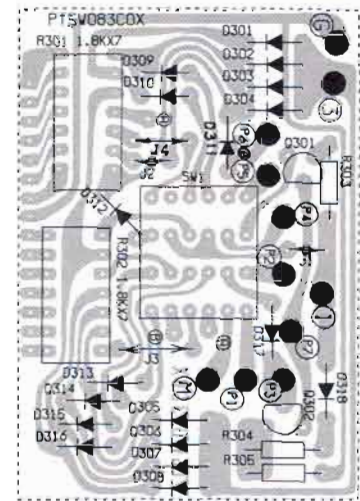

Channel Selector [PTSW083COX]

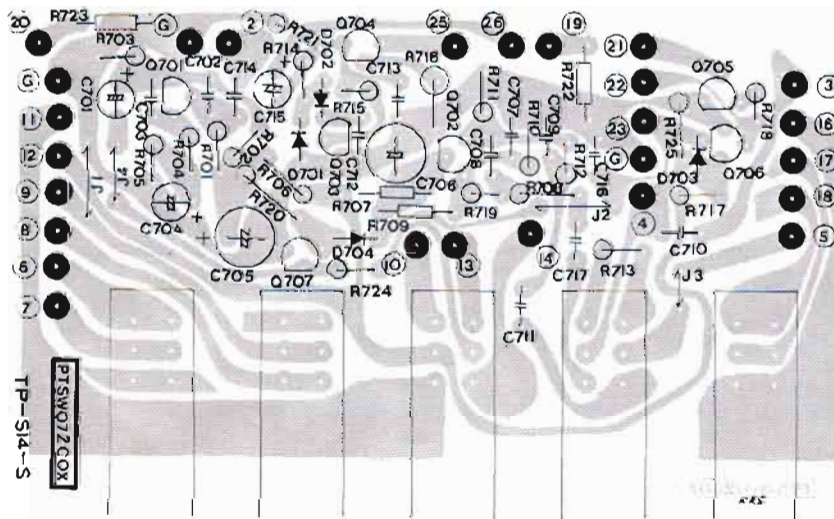

Lever Switches [PTSW072COX]

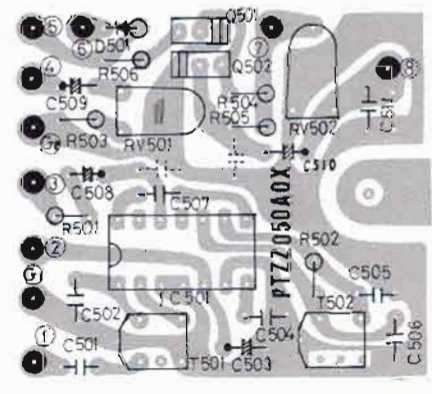

FM Circuit [PTZZ050AOX]

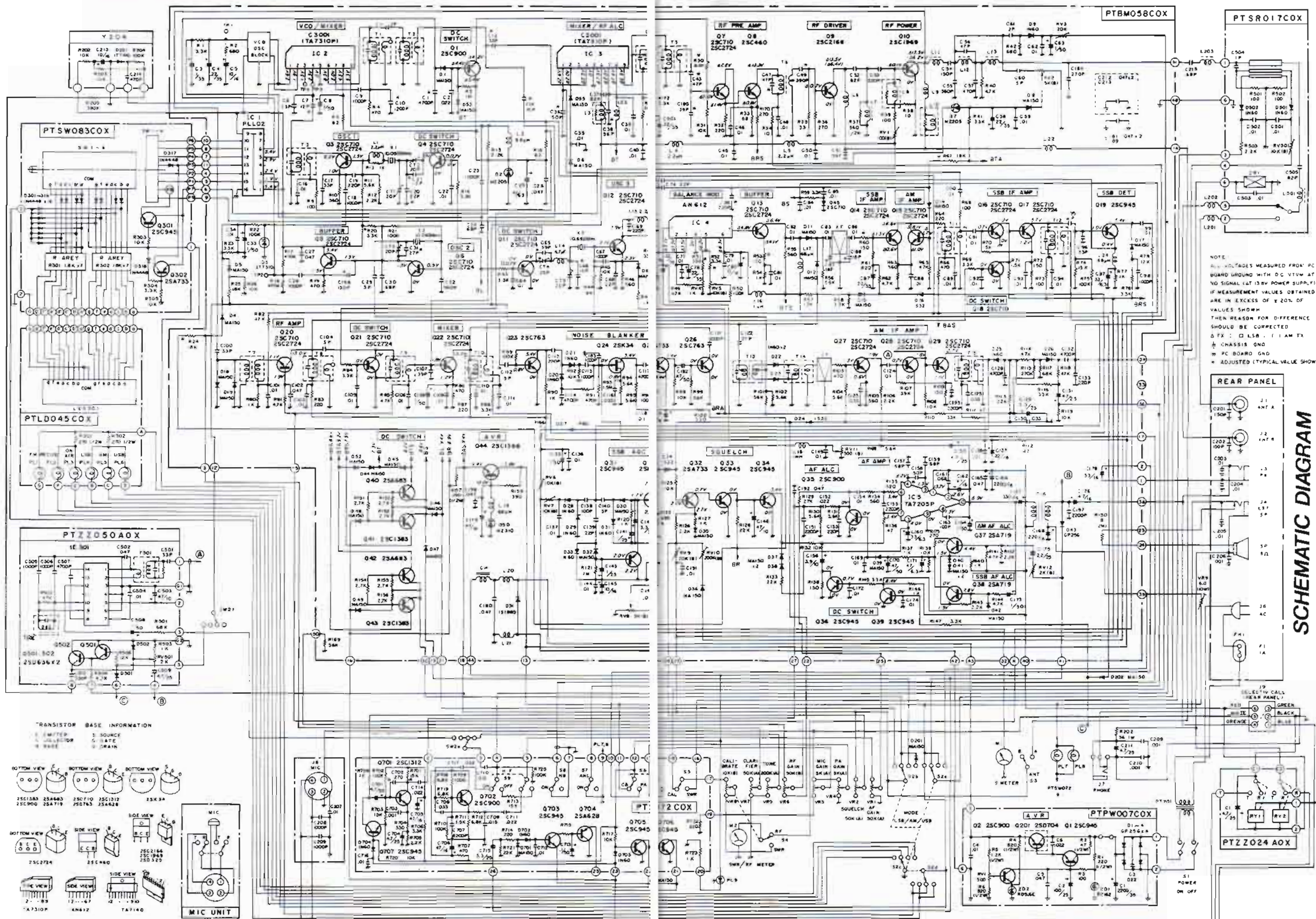

NOTE:
 ALL VOLTAGES MEASURED FROM PC BOARD GROUND WITH DC VTM AT NO SIGNAL (AT 13.5V POWER SUPPLY). IF MEASUREMENT VALUES OBTAINED ARE IN EXCESS OF ±20% OF VALUES SHOWN THEN REASON FOR DIFFERENCE SHOULD BE CORRECTED.
 Δ FX : □ DLSB : □ I AM TX
 ⊕ CHASSIS GND
 * PC BOARD GND
 * ADJUSTED (TYPICAL VALUE SHOWN)

SCHEMATIC DIAGRAM

TRANSISTOR BASE INFORMATION
 ○ EMITTER □ SOURCE
 △ BASE ○ DRAIN

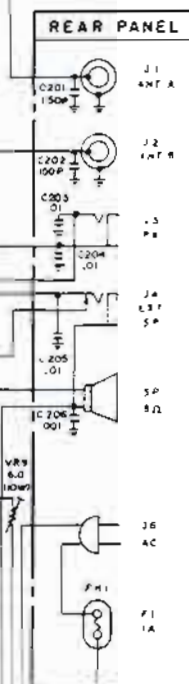
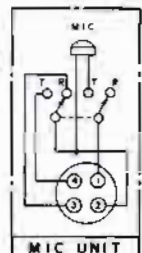
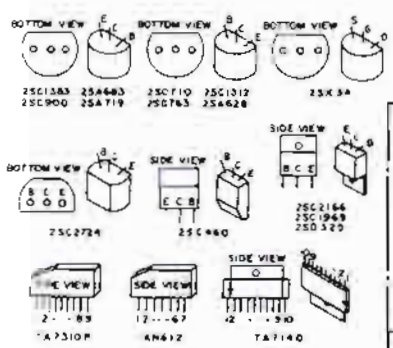

SELECT TO CALL REAR PANEL:
 GREEN
 BLACK
 BROWN

PTZ024 AOX

Made Exclusive For
SAGA TRADING AB
Box 6057 S-200 11 Malmö S

KT2555FMXX

Printed in Japan